

Dimensions and Shipping Weight

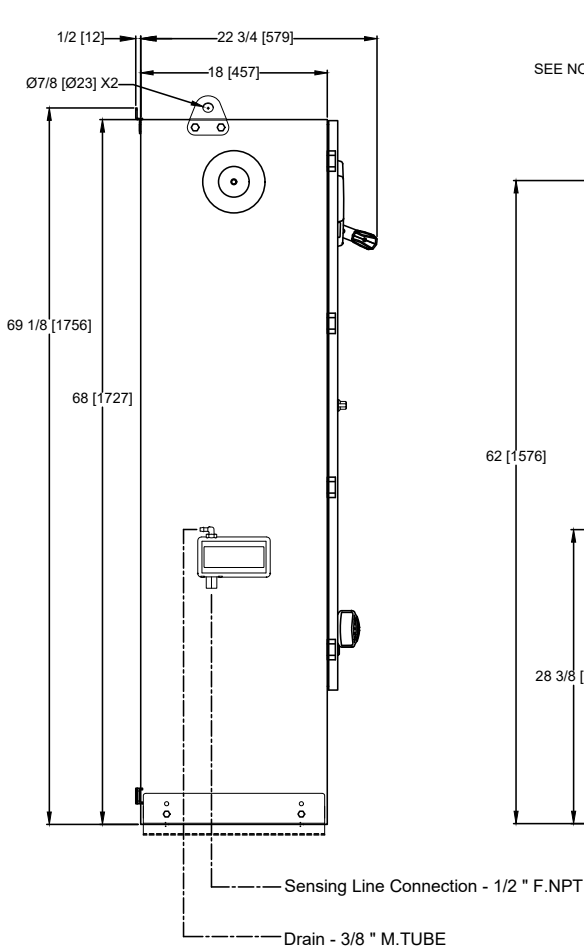

FTA1350

MARK III Electric Fire Pump Controllers - Wye-Delta Closed Transition Starting



NOTE:
DRAIN CONNECTION MUST BE PIPED TO WASTE DRAIN. FAILURE TO CONNECT TO A FLOOR DRAIN WILL RESULT IN UNSAFE CONDITIONS OF STANDING WATER AROUND CONTROLLER.

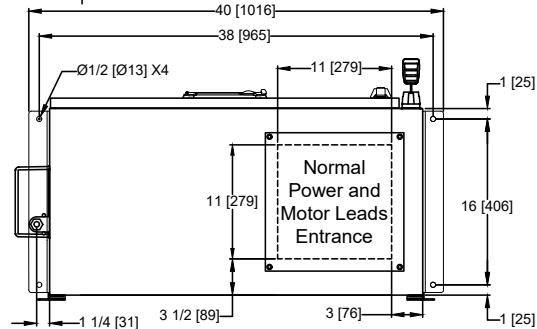
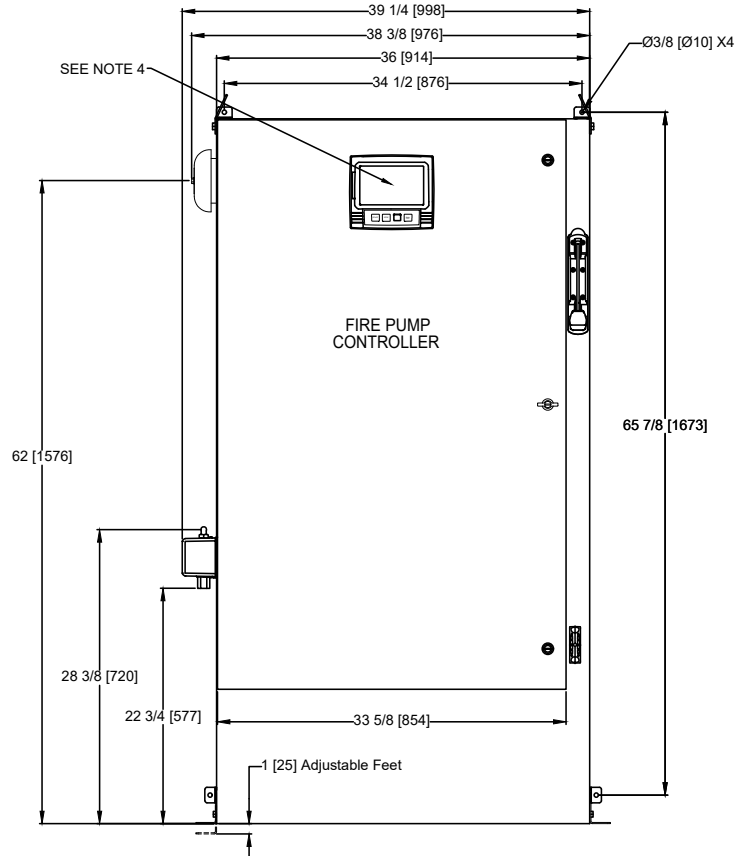

LINE VOLTAGE	MOTOR HORSEPOWER
208	75-150
220-240	100-200
380-400-415	150-300
440-480	200-450
600	250-500
APPROX SHIPPING WEIGHT: 765 [347]	

- NOTES:
- STANDARD: NEMA 2
 - STANDARD PAINT: TEXTURED RED RAL3002
 - ALL DIMENSIONS IN INCHES [MILLIMETERS]
SHIPPING WEIGHT IN POUNDS [KG]
 - CENTER OF MARK III SCREEN: 61 5/8 [1564] FROM BOTTOM OF ENCLOSURE
 - BOTTOM CONDUIT ENTRANCE THROUGH REMOVABLE GLAND PLATE RECOMMENDED
 - USE WATERTIGHT CONDUIT AND CONNECTOR ONLY
 - PROTECT EQUIPMENT AGAINST DRILLING CHIPS
 - DOOR SWING EQUAL TO DOOR WIDTH
 - DRAWINGS FOR CONSTRUCTION PURPOSES MUST BE OBTAINED FROM FIRETROL OR THE LOCAL FIRETROL REPRESENTATIVE
 - SEISMIC MOUNTING TO BE RIGID WALL AND BASE ONLY

THIRD ANGLE PROJECTION	SIZE	A	BY	CIR	DATE	11-5-19
	DRAWN BY	CIR	11-5-19			
	FINAL APPROVAL	CIR	11-5-19			



© Firetrol, Inc. Not for construction. Subject to change without notice.

REVISED VOLTAGE/POWER CHART		B	-	CIR	CIR	1-21-21
REVISION DESCRIPTION		REV	ECN NO	BY	APP	DATE
DIMENSIONS & SHIPPING WEIGHT		FTA1350		DRAWING NUMBER		
CLOSED TRANSITION WYE DELTA FIRE PUMP CONTROLLER				DD1350-72		
		DWG REV	A	ECN NO	-	SHEET 1 OF 1