

Dimensions and Shipping Weight

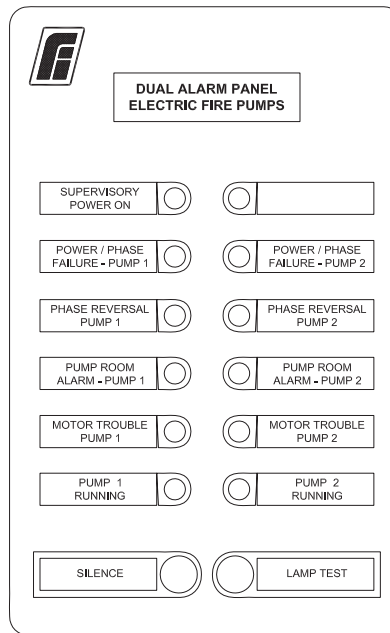

FTA200AA

Remote Alarm Panels for use with (2) Electric Fire Pump Controllers

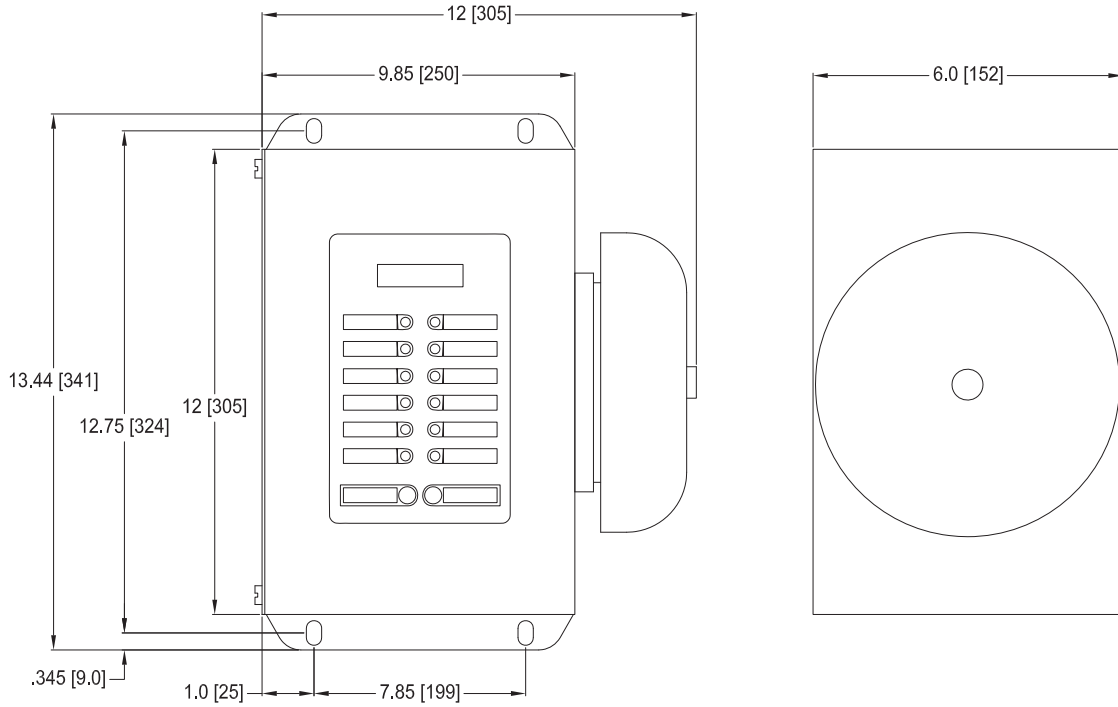

NOTES:

1. NEMA 1 ENCLOSURE
2. STANDARD PAINT: TEXTURED RED RAL3002
3. ALL DIMENSIONS: INCHES [MILLIMETERS]
SHIPPING WEIGHT: POUNDS [KG]
4. BUILT TO UL 508A STANDARD
5. DO NOT INSTALL IN AMBIENT TEMPERATURES BELOW 41°F [5°C]

APPROXIMATE SHIPPING WEIGHT
20 [9]

	SIZE	A	BY	JMW	DATE	11-01-19	NEW RELEASE	-	-	JMW	CIR	11-04-19
	DRAWN BY	JMW	DATE	11-01-19	REVISION DESCRIPTION	REV	ECN NO	BY	APP	DATE		
	FINAL APPROVAL	CIR	DATE	11-01-19	DIMENSIONS & SHIPPING WEIGHT	FTA200		DRAWING NUMBER		DD200AA-60		CDL
					ALARM PANEL FOR 2 ELECTRIC FIRE PUMP CONTROLLERS	DWG REV	-	ECN NO	-	SHEET 1 OF 1		



© Firetrol, Inc. Not for construction. Subject to change without notice.