

MARK^{III+} Variable Speed Electric Fire Pump Controller – Soft Start Bypass

Project Information

Voltage / Power Table		
Voltage	Min HP	Max HP
200	40	75
208 - 240	40	100
380 - 400 - 415	50	150
440 - 480	60	200
600	75	100

DRAWINGS INCLUDED IN THIS PACKAGE ARE FOR STANDARD CONTROLLERS. ACTUAL "AS BUILT" DRAWINGS MAY DIFFER FROM THOSE SHOWN HERE.

Firetrol, Inc.

3362 Apex Peakway
Apex, North Carolina 27502
P +1 919 460 5200
F +1 919 460 5250
www.firetrol.com

While every precaution has been taken to ensure accuracy and completeness herein, Firetrol, Inc. assumes no responsibility, and disclaims all liability, for damages resulting from use of this information or for any errors or omissions. Specifications and drawings are subject to change without notice.
©2023 Firetrol, Inc., All Rights Reserved.

Firetrol MarkIII+ Electric Fire Pump Controller

FTA3130S – Variable Speed Starting with Soft Starter Bypass Specifications

1.0 Main Fire Pump Controller

The MarkIII+ FTA 3130S provides a variable frequency drive (VFD) to control the speed of a centrifugal pump for the purpose of limiting the system pressure in a sprinkler system used for fire protection. The controller shall control a fire pump motor having the horsepower, voltage, phase and frequency rating shown on the plans and drawings. The controller shall be equipped with both automatic and manual bypass to start and run the motor should a problem arise with the VFD. The controller shall be provided with a soft starting bypass.

1.1 Standards, Listings & Approvals

The controller shall conform to all the requirements of the latest editions of:
NFPA 20, *Standard for the Installation of Stationary Pumps for Fire Protection*
NFPA 70, *National Electrical Code*.

The controller shall be listed by:

Underwriters Laboratories, Inc., in accordance with UL218, *Standard for Fire Pump Controllers* Canadian Standards Association CSA-C22.2, *Standard for Industrial Control Equipment* (cUL)

The controller shall be approved by:
Factory Mutual (IEC 62091)

1.2 Enclosure

The controller components shall be housed in a NEMA Type 12 (IEC IP54) drip-proof, floor mounted enclosure with powder coat finish. The enclosure shall include conductor entry gland plates, enclosure lifting brackets and lockable door.

1.3 Withstand Ratings (Short Circuit Current Ratings)

All controller components shall be front mounted, wired and front accessible for maintenance. The minimum withstand rating of the controllers shall not be less than 100,000 Amps RMS Symmetrical at 200-480 Volts and 50,000 Amps RMS at 600V. See product information for details.

1.4 Isolation Switch and Circuit Breaker

The controller shall include a motor rated combination isolating disconnect switch/circuit breaker, mechanically interlocked and operated with a single, externally mounted handle. The isolating disconnect switch/circuit breaker shall be mechanically interlocked so that the enclosure door cannot be opened with the handle in the ON position except by a hidden tool operated bypass mechanism. The isolating disconnect switch/circuit breaker shall be capable of being padlocked in the OFF position for installation and maintenance safety, and shall also be capable of being locked in the ON position without affecting the tripping characteristics of the circuit breaker. The circuit breaker trip curve adjustment shall be factory set and tested.

1.5 Operator Interface

The operator interface shall be a 7.0" LCD color touch screen (HMI technology) powered by an embedded microcomputer with software PLC logic. Included shall be keypad type push-buttons for START, STOP, RUN TEST and TRANSFER SWITCH TEST.

The screen shall include menus for: *Home · Alarms · Configuration · History · Service · Manuals · Language*.

The HMI shall graphically display the following: *Voltage and Amperage of all 3 phases simultaneously using true RMS Technology for both the Normal and Alternate Power Sources · Transfer Switch Status · Motor Stopped/Running · Starting Cause · Actuation Mode · Controller Type · Shut-down Mode · Date & Time · Pump Room Temp. · System Pressure*
System pressure shall be capable of being displayed as: *PSI, kPa, Bar, Feet of Head or Meters of Water.*

The HMI shall allow programming and display of: *Cut In & Cut Out Pressure Settings · Minimum Run Timer · Sequential Start Timer · Periodic Test Timer*

The controller shall provide visual indication for: *VFD Fault · VFD Bypass · Locked Rotor Current · Failed to Start · Under/Over Current · Over/Under Voltage · Phase Imbalance · Phase Reversal · Transducer Fault · Low Pump Room Temperature*

The HMI allows the user to select the language of the system and download the manual or view the manual on screen.

1.6 Ammeter/Voltmeter

The fire pump controller operator interface shall be capable of displaying true RMS digital motor voltage and current measurements for all three phases simultaneously. Displays requiring push-button and selector switches to toggle between phases or current and voltage shall not be accepted. Voltage and current shall be measured by True RMS technology to provide the most accurate measurement for all sine waves, including non-sinusoidal waveforms. Average responding meters will not be accepted.

1.7 Solid State Pressure Transducers

The controller shall be supplied with two solid state pressure transducers with a operating range of 0-500 psi (0-34.5 bar) ±1 psi. One transducer shall be an input to the MarkIII+ and for display of the system pressure and the other transducer shall be a pressure input to the drive for speed control. Start, Stop and System Pressure shall be digitally displayed and adjustable through the user interface. Field connections shall be made externally at the controller couplings to prevent distortion of the pressure sensing elements.

1.8 VFD Modes of Operation

The controller shall operate a variable frequency drive (VFD) to control the speed of a centrifugal pump for the purpose of limiting the system pressure in a sprinkler system used for fire protection. The drive controls the speed of the AC induction motor driving the pump to maintain the system pressure at the set point.

The operator interface as the overall fire pump control device is to respond automatically to a low pressure condition with a call to start of the VFD. The MarkIII+ shall monitor and control the operation of the VFD. The VFD shall be entirely configured by the MarkIII+.

Upon detection of a failure in the drive, it shall bypass and isolate the VFD through the line and load isolation contactors, and run the pump via the Soft Starter at rated speed. The operator may choose to manually operate the drive in BYPASS or VFD. Operation in Bypass mode produces both an audible local alarm and a remote alarm for annunciation of an abnormal condition in the controller.

Set pressure is maintained until the min. run time of 10 minutes expires whereupon the controller temporarily lowers the set pressure in order to ramp the drive down sufficiently in speed to perform a sincerity check on system pressure for a period of 5-10 seconds. If system pressure remains above the start pressure during the sincerity check, then system pressure is stable, indicating there is no longer a demand for flow. Since the low pressure condition no longer exists, the MarkIII+ soft stops the drive.

1.9 VFD Mode - Manual Operation

The pump may be operated manually via the local start and stop push-buttons. If the VFD is Ready, the controller will soft start the drive which will ramp the pump up to the speed required to maintain set pressure.

Set pressure is maintained until the operator presses stop, whereupon the controller temporarily lowers the set pressure in order to ramp the drive down sufficiently in speed to perform a sincerity check on system pressure for a period of 5-10 seconds. If system pressure remains above the start pressure during this sincerity check, then system pressure is stable, indicating there is no longer a demand for flow, and the MarkIII+ proceeds to soft stop the drive.

If system pressure falls below the start pressure during the sincerity check, a low pressure condition has developed which the MarkIII+ recognizes as an automatic call to start. The MarkIII+ responds to the call to start by ramping the pump back up set pressure. The controller will continue operating in automatic until system pressure stabilizes indicating there is no longer a demand for flow.

2.0 VFD Mode - Emergency Run

If an attempt to engage the emergency run bar is made in VFD mode, the MarkIII+ shall drop the drive out of the circuit and go to bypass using the hard stop drive procedure. An over pressure event will be captured and displayed as an alarm message on the MarkIII+ if system pressure is equal to or greater than 115% of Set pressure. A time delay used in the Over Pressure alarm logic shall be applied to avoid nuisance alarms.

2.1 Weekly Test and Service Message

Controller shall have the ability to program the time, date, and frequency of the weekly test. In addition, the controller shall have the capability to display a preventative maintenance message for a service inspection. The message text and frequency of occurrence shall be programmable through the user interface.

2.2 Power Transfer Switch (If ordered)

The power transfer switch shall be NEMA Type 12 (IEC IP54) drip-proof enclosure attached directly to or in close proximity to the fire pump controller. The fire pump controller/power transfer switch shall be factory assembled, wired and tested as a unit prior to shipment. Voltage and frequency on both the normal and emergency sources shall be continuously monitored. Source status screens shall be provided for both normal and emergency to provide digital readout of voltage frequency and phase rotation on all 3 phases.

2.3 Event Recording

Memory - The controller shall record all operational and alarm events to system memory. All events shall be time and date stamped and include an index number. The system memory shall have the capability of storing events and allow the user access to the event log via the user interface. The user shall have the ability to scroll through the stored messages.

2.4 USB Host Controller

The controller shall have a built-in USB Host Controller. A USB port capable of accepting a USB Flash Memory Disk shall be provided. The controller shall save all operational and alarm events to the flash memory on a daily basis. Each saved event shall be time and date stamped. The total amount of historical data saved shall solely depend on the size of the flash disk utilized. The controller shall have the capability to save settings and values to the flash disk on demand via the user interface.

2.5 Manufacturer

The controller shall be a Firetrol brand.

3412 Apex Peakway
Apex, North Carolina 27502
P +1 919 460 5200
F +1 919 460 5250
www.firetrol.com

Firetrol, Inc.

While every precaution has been taken to ensure accuracy and completeness herein, Firetrol, Inc. assumes no responsibility, and disclaims all liability, for damages resulting from use of this information or for any errors or omissions. Specifications and drawings are subject to change without notice. ©2019 Firetrol, Inc., All Rights Reserved.

Publication SP3130S-10



Product Description

FTA3100S, 3130S

MarkIII+ Electric Fire Pump Controllers

Variable Speed Starting



Description – Firetrol® Variable Speed Electric Fire Pump Controllers provide a variable frequency drive (VFD) to control the speed of a centrifugal pump for the purpose of limiting system pressure in a fire sprinkler system. These controllers are available in the following configurations:

FTA3100S – VFD with Across-the-Line Bypass

FTA3130S – VFD with Digital Soft Start Bypass

Approvals – Firetrol fire pump controllers are listed by Underwriters' Laboratories, Inc., in accordance with UL218, *Standard for Fire Pump Controllers*, CSA, *Standard for Industrial Control Equipment*. They are built to meet or exceed the requirements of the approving authorities as well as NEMA, the latest editions of NFPA 20, *Installation of Centrifugal Fire Pumps*, NFPA 70, *National Electrical Code* and are approved by Factory Mutual.

Standard Features—The following are included as standard with each controller:

- Voltage surge protector
- Main Disconnect Switch sized for connected motor horsepower and voltage
- Fire pump Circuit Breaker

- Single handle Isolating Disconnect Switch/Circuit Breaker mechanism
- Motor contactor
- Emergency Manual Run Mechanism to mechanically close motor contactor contacts in an emergency condition
- Built-in Start and Stop push-buttons to bypass automatic start circuits
- Minimum Run Timer / Off Delay Timer
- Daylight Savings Time Option
- Weekly Test Option
- Elapsed Time Meter
- 7" LCD color touch screen with Embedded microcomputer with software PLC Logic. Keypad type push-buttons for Start/Stop/Test
- The screen shall display:
 - Voltage and amperage using true RMS technology
 - Motor Frequency (Hz)
 - Pump Running
 - Starting Cause
 - Time and Date
 - Shutdown Method
 - Pump Room Temperature
 - Pressure gauge showing start/stop/current pressure reading

Visual Indication for:

- VFD Fault
- VFD Bypass
- Locked Rotor Current
- Failed to Start
- Under/Over Current
- Under/Over Voltage
- Phase Imbalance
- Transducer Fault
- Motor Trouble
- Pump Room Alarm
- Phase Reversal
- Power/Phase Loss
- Low Water Level
- Pump on Demand
- Low Pump Room Temp.
- Service Required

Pressure and Event Recording

- Logs Pressure Data and Operational Events with time and date stamp.
- Data can be retrieved via USB port or via Wi-Fi using the M3Sync App.

Wet Parts

- Controller supplied with 2 pressure transducers and a test solenoid rated for 500 psi working pressure. Part shall be externally mounted with have a protective cover. Pressure sensing line to be 1/2" FNPT.

FOR MODEL # INFORMATION SEE
PUBLICATION SD3100S-10

FOR OPTIONS AND MODIFICATIONS SEE
PUBLICATION OP3100S-10

Firetrol, Inc.

3362 Apex Peakway
Apex, North Carolina 27502
P +1 919 460 5200
F +1 919 460 5250
www.firetrol.com

While every precaution has been taken to ensure accuracy and completeness herein, Firetrol, Inc. assumes no responsibility, and disclaims all liability, for damages resulting from use of this information or for any errors or omissions. Specifications and drawings are subject to change without notice. ©2023 Firetrol, Inc., All Rights Reserved.

Publication PD3100S-10



Model Number Selection Guide

FTA3100S, 3130S

MarkIII+ Electric Fire Pump Controllers

Variable Speed Starting

VARIABLE SPEED ELECTRIC FIRE PUMP CONTROLLERS

Example: FTA3130S-AM75B-xx

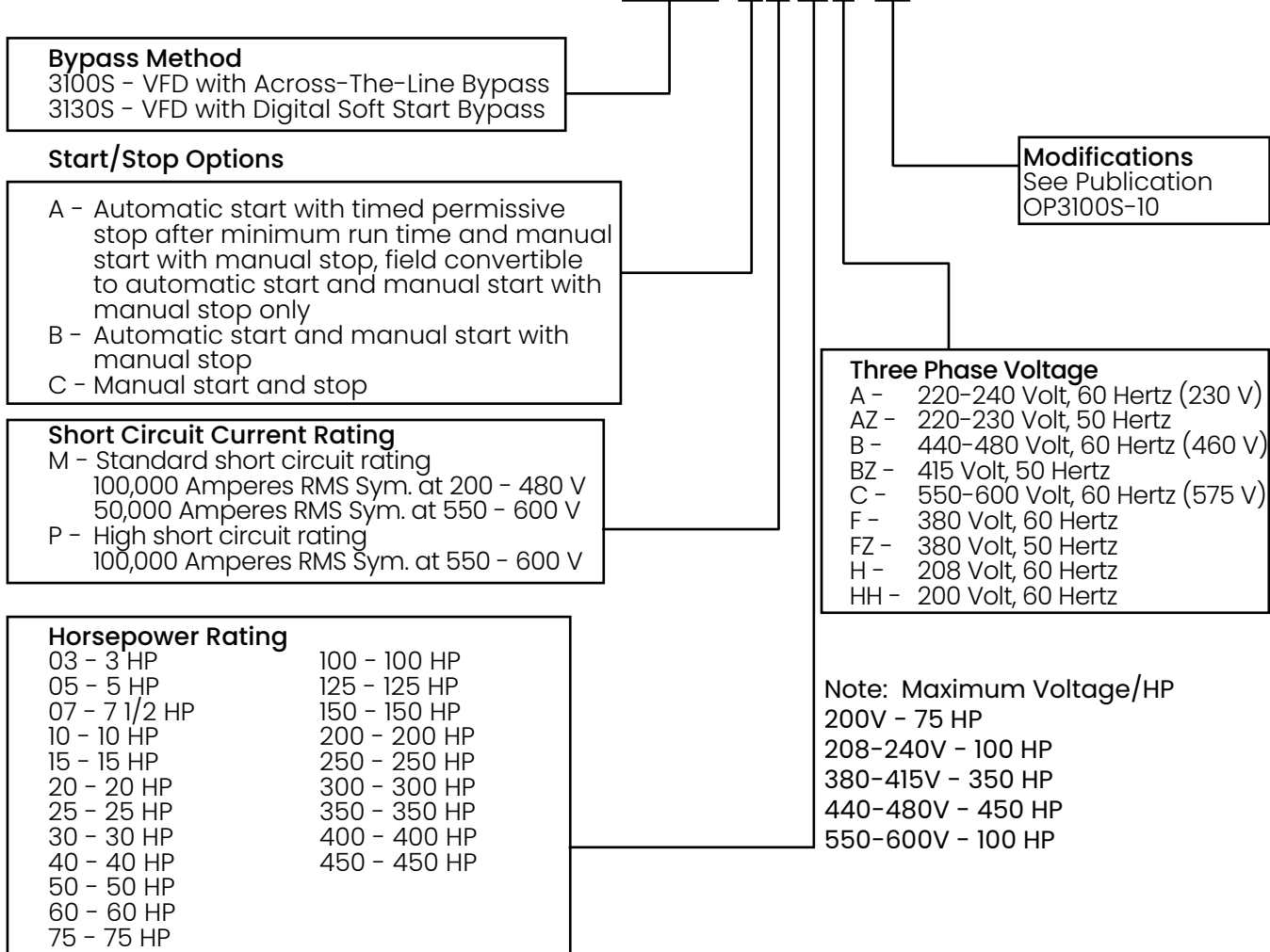

Firetrol, Inc.

3362 Apex Peakway
Apex, North Carolina 27502
P +1 919 460 5200
F +1 919 460 5250
www.firetrol.com

While every precaution has been taken to ensure accuracy and completeness herein, Firetrol, Inc. assumes no responsibility, and disclaims all liability, for damages resulting from use of this information or for any errors or omissions. Specifications and drawings are subject to change without notice. ©2023 Firetrol, Inc., All Rights Reserved.



MARK^{III+} Variable Speed Electric Fire Pump Controllers

SPECIAL ENCLOSURES

Option	Description
---	Enclosure, NEMA Type 12 (IEC IP54), Painted Steel (Standard)

CIRCUIT BREAKER OPTION*

Option	Description				
	Standard Short Circuit Current Rating				
-M	200V 5-75 HP 100kA (M)	208-240V 5-100 HP 100kA (M)	380-415V 5-350 HP 100kA (M)	440-480V 5-450 HP 100kA (M)	550-600V 5-100 HP 50kA (M)
	High Short Circuit Current Rating				
-P	N/A	N/A	N/A	N/A	550-600V 5-100 HP 100kA

ANTI-CONDENSATION SPACE HEATERS

Option	Description
None	
-J	Space Heater, 120V Externally Powered with Circuit Breaker & Thermostat
-K	Space Heater, 120V Externally Powered with Circuit Breaker & Humidistat
-M	Space Heater, 240V Externally Powered with Circuit Breaker & Thermostat
-N	Space Heater, 240V Externally Powered with Circuit Breaker & Humidistat
-JKP	Space Heater, 120V Externally Powered with Circuit Breaker, Thermostat and Humidistat in Parallel
-MNP	Space Heater, 240V Externally Powered with Circuit Breaker, Thermostat and Humidistat in Parallel

PRESSURE TRANSDUCERS, SOLENOID VALVES, PLUMBING

Option	Description
---	Wetted Parts including Pressure Sensor and Test Solenoid, 300 PSI (20.4 Bar) Fresh Water
-B1	Wetted Parts including Pressure Sensor and Test Solenoid, 500 PSI (34.5 Bar) Fresh Water (For Factory Calibration Purposes Only)
-C1	Wetted Parts including Pressure Sensor and Test Solenoid, 300 PSI (20.4 Bar), Sea Water
-D1	Wetted Parts including Pressure Sensor and Test Solenoid, 500 PSI (34.5 Bar), Sea Water
-SP1	Low Suction Pressure Transducer, Fresh Water, 0-300 PSI (20.4 Bar) with Visible Indication and Output Contacts
-SP2	Low Suction Pressure Transducer, Sea Water, 0-300 PSI (20.4 Bar) with Visible Indication and Output Contacts

ALARMS

Option	Description
-AC	Extra Alarm Output Contacts, Pump Operating (2 Form-C)
-AM	Alarm Output Contacts, Fail to Start
-AV	Alarm Output Contacts, Low Pump Room Temperature
-AW	Alarm Output Contacts, Reservoir Low
-AYI	Configurable Low Suction Pressure, Visible/Output Contacts with External Digital Input
-BWI	Extra Alarm Output Contacts, Phase Failure/Phase Reversal
-BYI	Alarm Output Contacts, Overcurrent
-CTSI	Configurable Low Suction Pressure, Visible/Output Contacts with Suction Pressure Transducer
-EHI	Alarm Output Contacts, Main Relief Valve Open
-EK	Alarm Output Contacts, Flow Meter Open
-JR	Visible Indicator, Jockey Pump Operating
-JT	Alarm, Audible/Visible, Jockey Pump Trouble
-KH	Alarm Output Contacts, Common Alarm
-PI	Alarm, Audible/Visible, Built-In 120V Supervisory System (Includes Visible Supervisory Voltage Normal Indication and Audible Pump Operating, Phase Failure and Phase Reversal Indication)
-PE	Alarm Output Contacts, Low System Pressure (Pump on Demand)
-PT	Alarm, Audible/Visible, Built-In 240V Supervisory System (Includes Visible Supervisory Voltage Normal Indication and Audible Pump Operating, Phase Failure and Phase Reversal Indication)

MISCELLANEOUS

Option	Description
-ED2	Normal Source Load Shedding with Adjustable Time Delay to Remove Non-Critical Loads Before Starting
-EL	Series Pumping Operation, High Zone Controller
-EM	Series Pumping Operation, Mid Zone Controller
-EN	Series Pumping Operation, Low Zone Controller
-MZN	Neutral Lug, Service Entrance, Non-Insulated Bonded to Enclosure
-OSP	Seismic Certification compliant to OSHPD (CA) for rigid base or wall mount only
-PK	Terminal Blocks, Extra Remote Start
-PY	Output Contacts, Motor Space Heater, Externally Powered
-S	Tropicalization
-SEI	Seismic Certification compliant to CBC 2019, IBC 2018 for rigid base or wall mount only
-USBX	Data Port, External USB
-ZPMI	Data Port, RS-485 Modbus RTU
-XCR	Export Packaging (Wooden Crating to Conform to IPPC Standards)

Firetrol, Inc.

3362 Apex Peakway
Apex, North Carolina 27502
P +1 919 460 5200
F +1 919 460 5250
www.firetrol.com

While every precaution has been taken to ensure accuracy and completeness herein, Firetrol, Inc. assumes no responsibility, and disclaims all liability, for damages resulting from use of this information or for any errors or omissions. Specifications and drawings are subject to change without notice. ©2023 Firetrol, Inc. All Rights Reserved.



© Firetrol, Inc. Not for construction.
Subject to change without notice.

BY		DD/MM/YY	
DRAWN BY	ZS	10/07/23	
FINAL APPROVAL	FC	10/07/23	

ELECTRIC FIRE PUMP CONTROLLER

MODEL: FTA3100S / FTA3130S

BUILT TO THE LATEST EDITION OF THE NFPA20 & NFPA70



THIRD ANGLE PROJECTION

DRAWING NUMBER	DD31X0S-803/E
DWG REV. 0	
SHEET 1 OF 1	

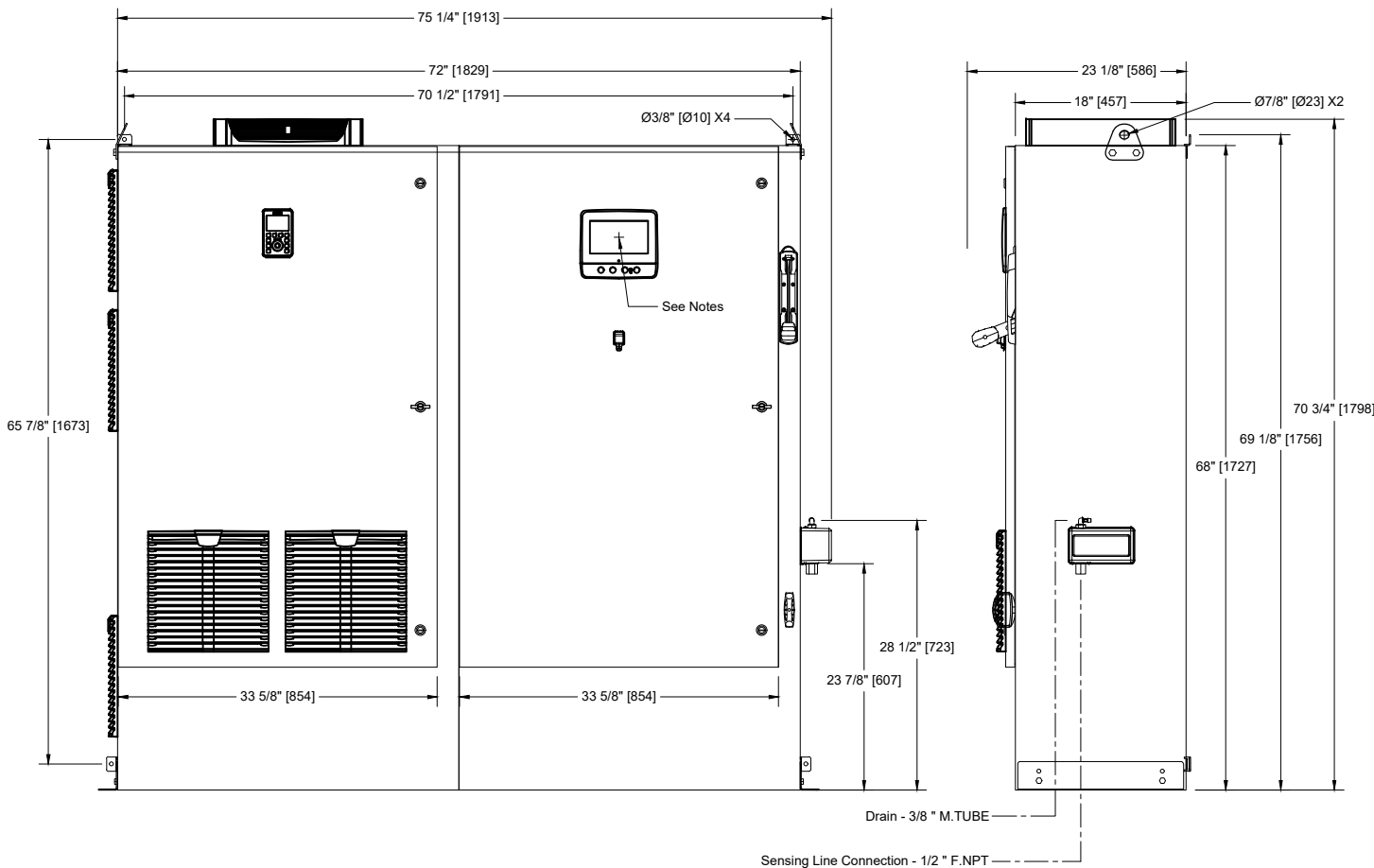

Voltage	Min HP	Max HP
200	40	75
208 - 240	40	100
380 - 400 - 415	50	150
440 - 480	60	200
600	75	100

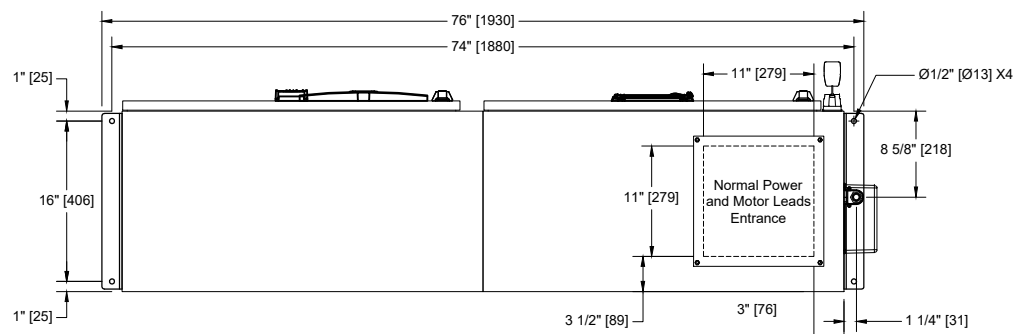

Notes:

- Standard: NEMA 12
- Standard paint : textured red RAL 3002.
- All dimensions are in inches [millimeters].
- Center of screen: 29-5/8" [751] from bottom (no feet).
- Bottom conduit entrance through removable gland plate recommended.
- Use watertight conduit and connector only.
- Protect equipment against drilling chips.
- Door swing equal to door width.



© Firetrol, Inc. Not for construction.
Subject to change without notice.

BY		DD/MM/YY
DRAWN BY	ZS	10/07/23
FINAL APPROVAL	FC	10/07/23

ELECTRIC FIRE PUMP CONTROLLER VARIABLE SPEED / SOFT STARTER BYPASS STARTING

MODEL: FTA3130S

BUILT TO THE LATEST EDITION OF THE NFPA20 & NFPA70



DRAWING NUMBER	WS3130S-800/E
DWG REV. 0	
SHEET 1 OF 4	

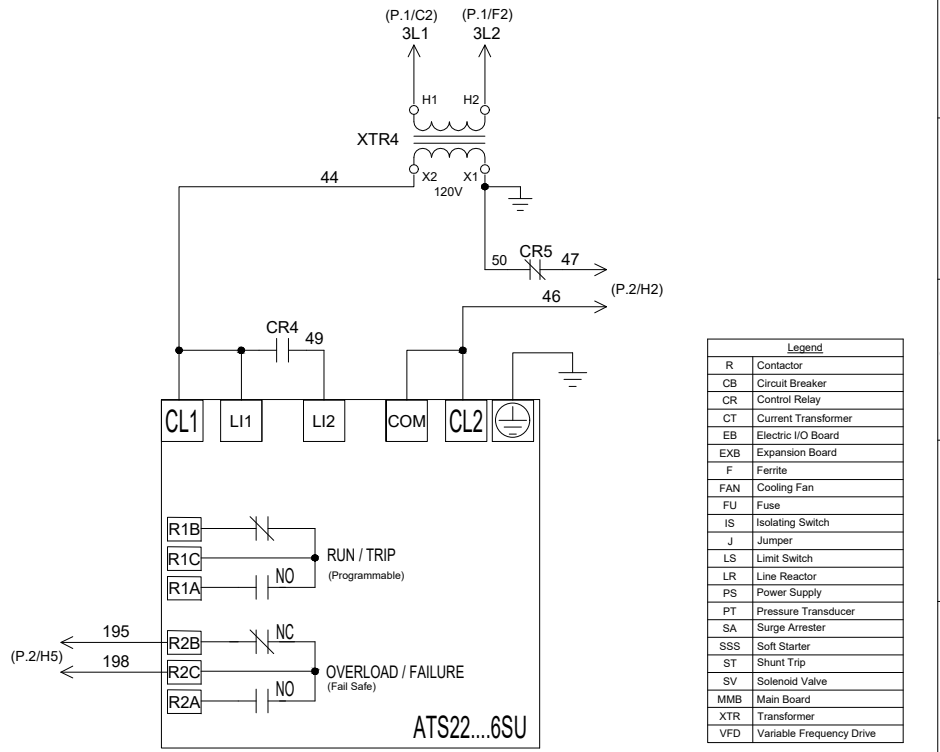
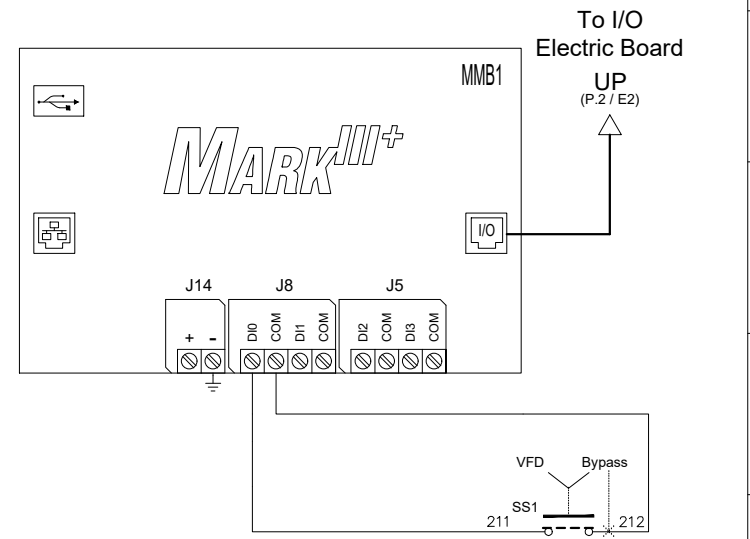
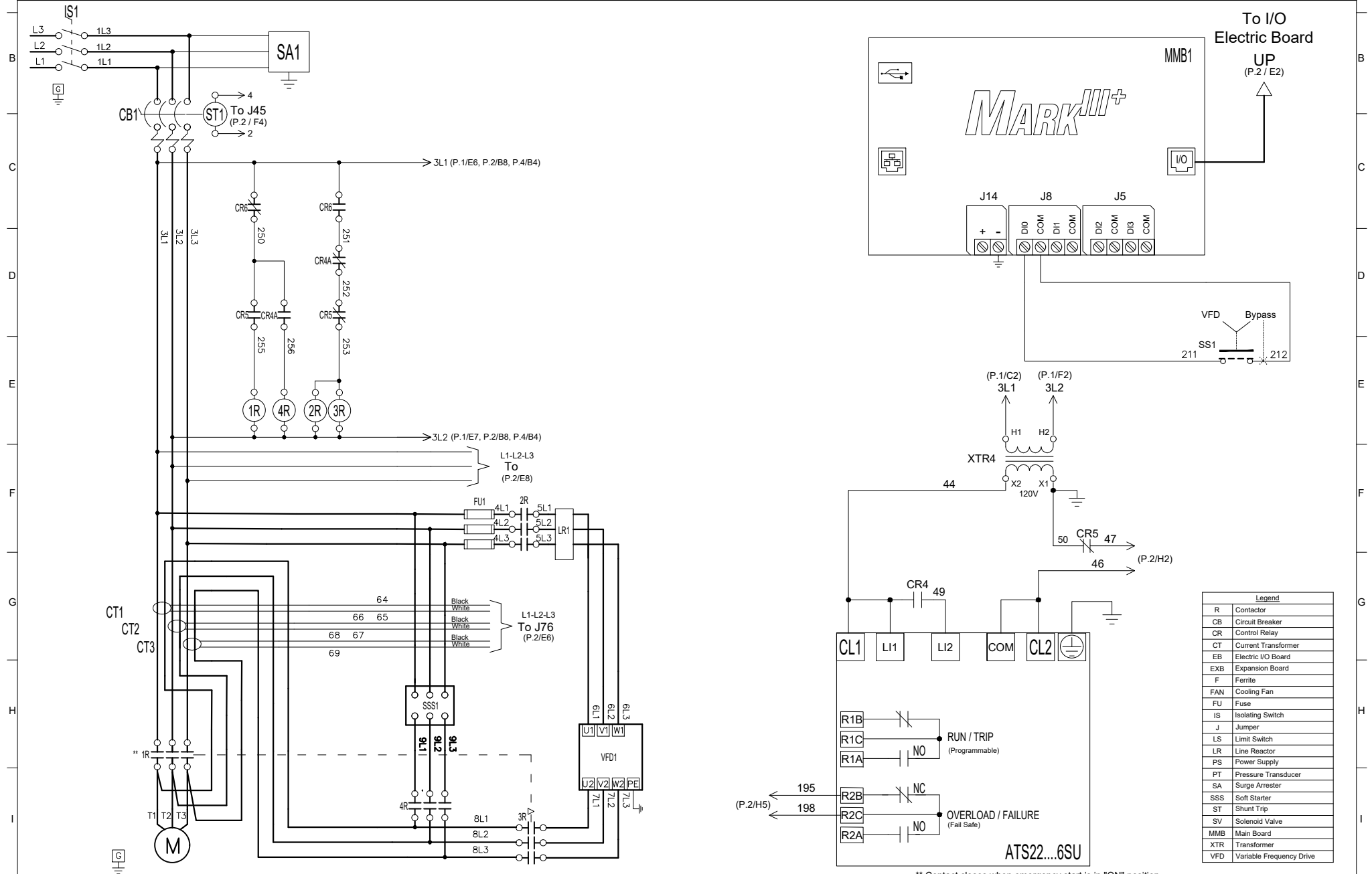

Legend	
R	Contact
CB	Circuit Breaker
CR	Control Relay
CT	Current Transformer
EB	Electric I/O Board
EXB	Expansion Board
F	Ferrite
FAN	Cooling Fan
FU	Fuse
IS	Isolating Switch
LS	Limit Switch
LR	Line Reactor
PS	Power Supply
PT	Pressure Transducer
SA	Surge Arrester
SSS	Soft Starter
ST	Shunt Trip
SV	Solenoid Valve
MMB	Main Board
XTR	Transformer
VFD	Variable Frequency Drive

** Contact closes when emergency start is in "ON" position.



© Firetrol, Inc. Not for construction.
Subject to change without notice.

BY DD/MM/YY	
DRAWN BY ZS	10/07/23
FINAL APPROVAL FC	10/07/23

ELECTRIC FIRE PUMP CONTROLLER VARIABLE SPEED / SOFT STARTER BYPASS STARTING

MODEL: FTA3130S

BUILT TO THE LATEST EDITION OF THE NFPA20 & NFPA70



DRAWING NUMBER WS3130S-800/E
DWG REV. 0
SHEET 2 OF 4

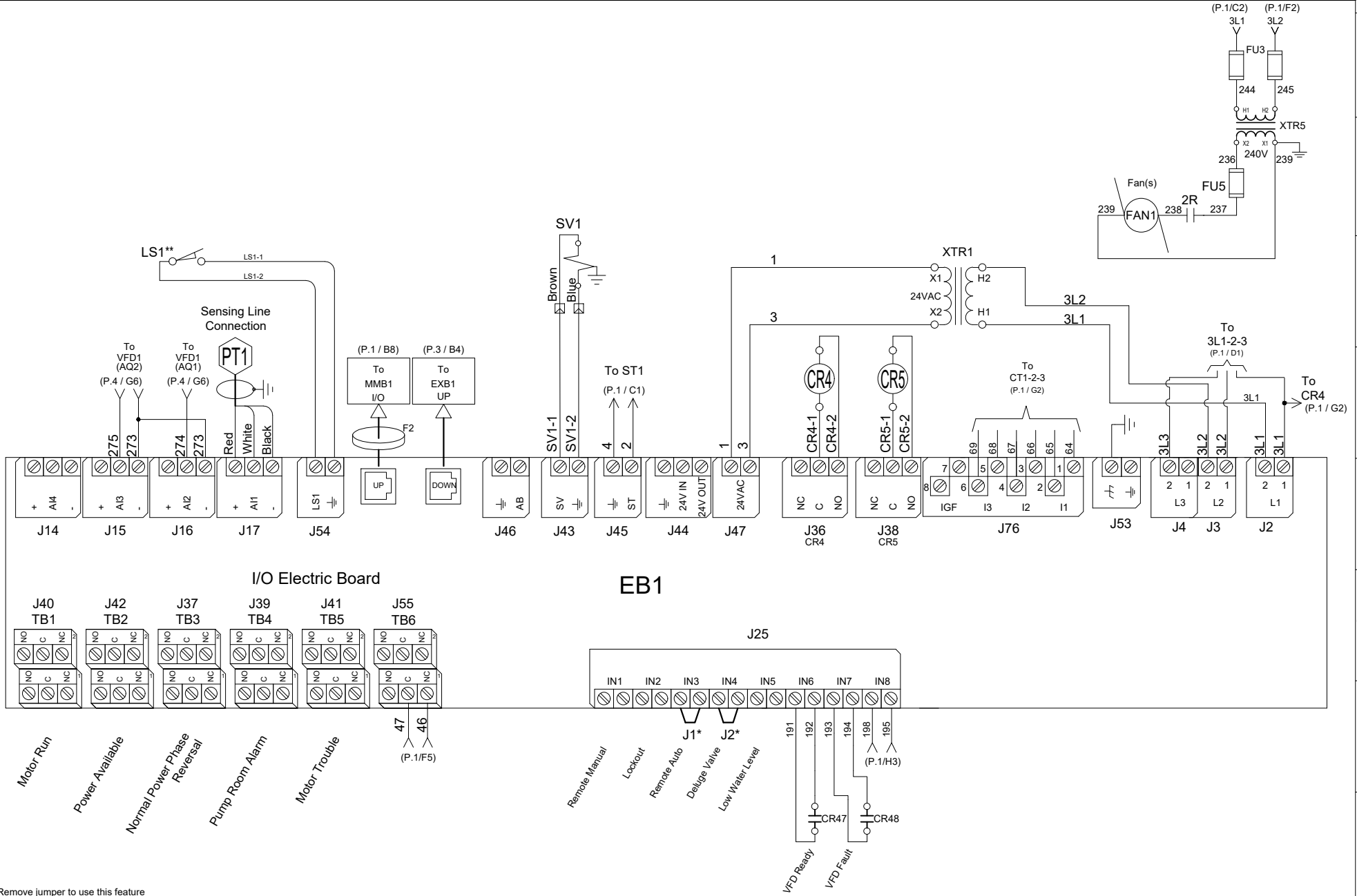

* Remove jumper to use this feature
** Contact closes when emergency start is in "ON" position



© Firetrol, Inc. Not for construction.
Subject to change without notice.

BY		DD/MM/YY	
DRAWN BY	ZS	10/07/23	
FINAL APPROVAL	FC	10/07/23	

ELECTRIC FIRE PUMP CONTROLLER VARIABLE SPEED / SOFT STARTER BYPASS STARTING

MODEL: FTA3130S

BUILT TO THE LATEST EDITION OF THE NFPA20 & NFPA70



DRAWING NUMBER	WS3130S-800/E
DWG REV. 0	
SHEET 3 OF 4	

Expansion Board 1

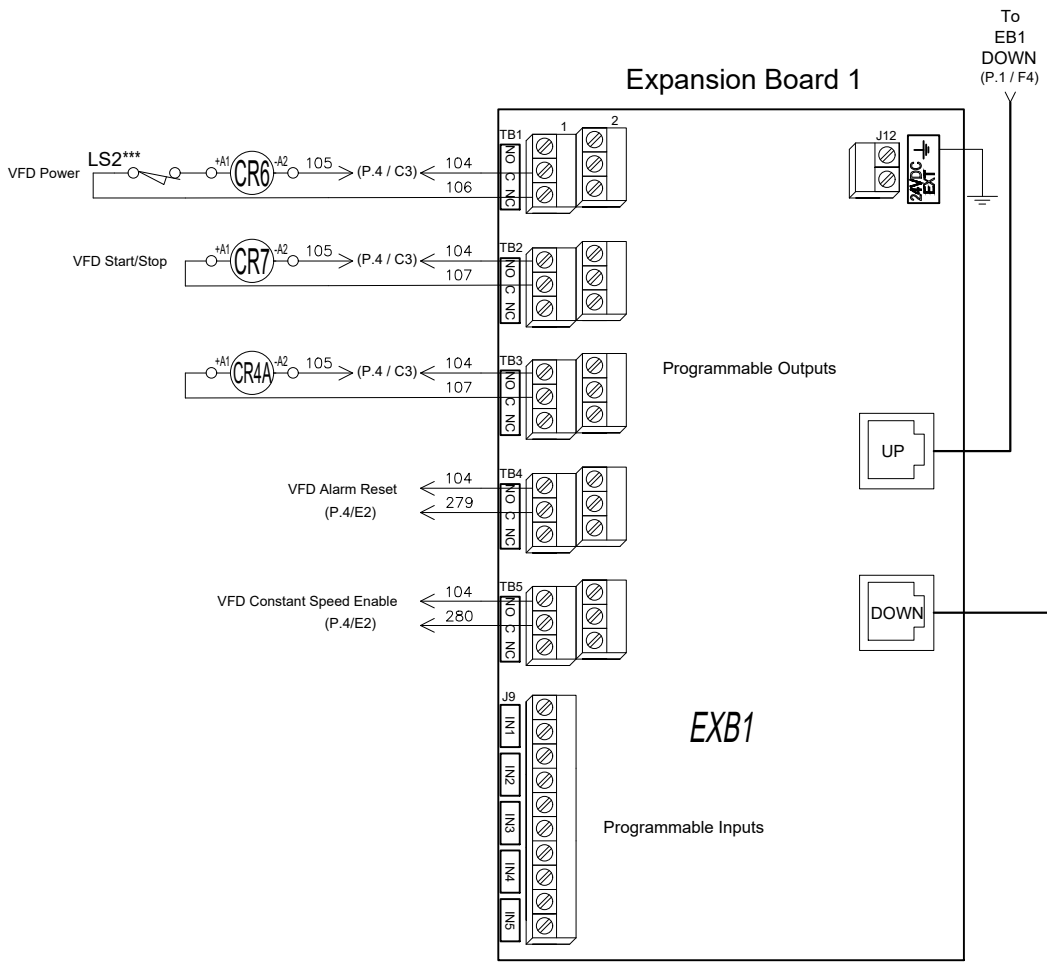

Expansion Board 2

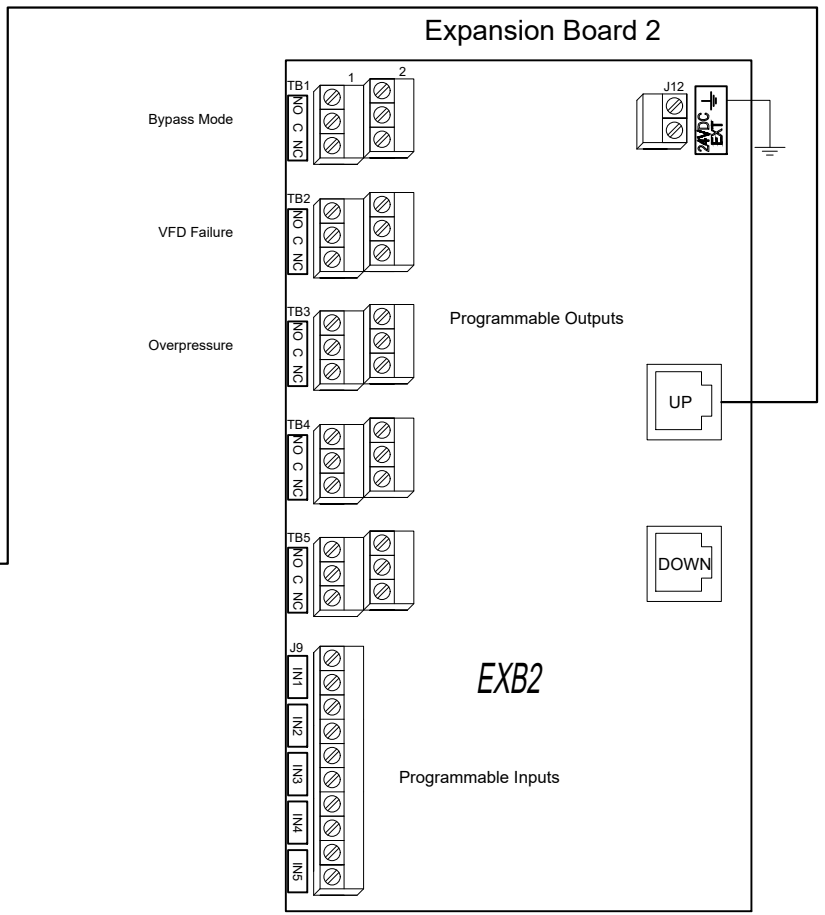

*** Contact opens when emergency start is in "ON" position



© Firetrol, Inc. Not for construction.
Subject to change without notice.

BY		DD/MM/YY
DRAWN BY	ZS	10/07/23
FINAL APPROVAL	FC	10/07/23

ELECTRIC FIRE PUMP CONTROLLER VARIABLE SPEED / SOFT STARTER BYPASS STARTING

MODEL: FTA3130S

BUILT TO THE LATEST EDITION OF THE NFPA20 & NFPA70



DRAWING NUMBER	WS3130S-800/E
DWG REV. 0	
SHEET 4 OF 4	

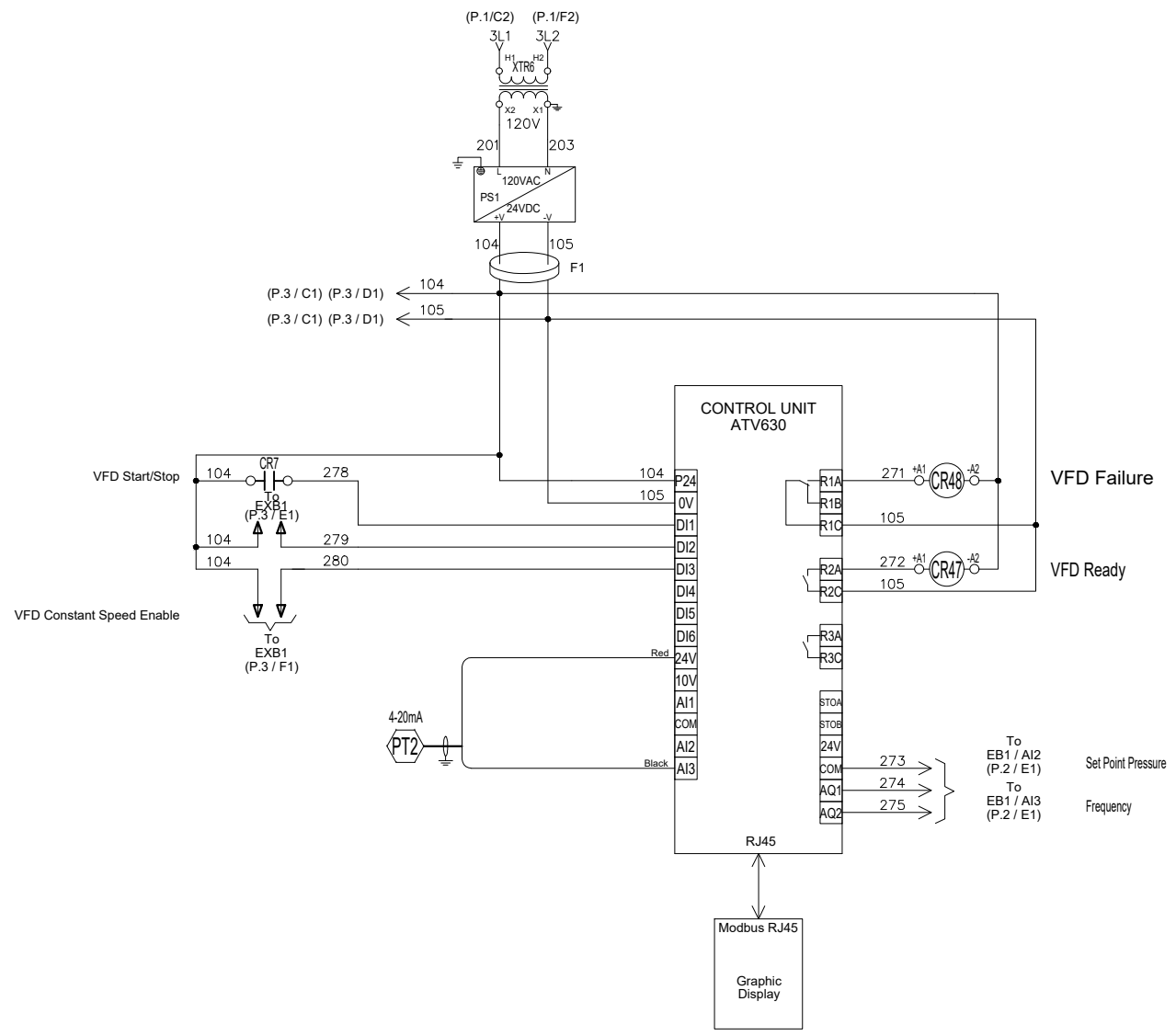



© Firetrol, Inc. Not for construction.
Subject to change without notice.

BY		DD/MM/YY	
DRAWN BY	ZS	10/07/23	
FINAL APPROVAL	FC	10/07/23	

ELECTRIC FIRE PUMP CONTROLLER

MODEL:FTA3100S / FTA3130S

BUILT TO THE LATEST EDITION OF THE NFPA20 & NFPA70



DRAWING NUMBER	FC31X0S-800/E
DWG REV. 0	
SHEET 1 OF 1	

COPPER CONDUCTORS for Isolating Switch (IS1).

Field Wiring According to Bending Space (AWG or MCM). Terminals L1 - L2 - L3

Bending Space	5" (127 mm)							8" (203 mm)			12" (305 mm)	
HP Voltage	5	7.5	10	15	20	25	30	40	50	60	75	100
200	1x (10 to 1/0)	1x (8 to 1/0)	1x (8 to 1/0)	1x (6 to 1/0)	1x (4 to 1/0)	1x (3 to 1/0)	1x (2 to 1/0)	1x (1/0 to 3/0)	1x (3/0 to 250)	1x (4/0 to 250)	2x (1/0 to 500)	-----
208	1x (10 to 1/0)	1x (8 to 1/0)	1x (8 to 1/0)	1x (6 to 1/0)	1x (4 to 1/0)	1x (3 to 1/0)	1x (2 to 1/0)	1x (1/0 to 3/0)	1x (3/0 to 250)	1x (4/0 to 250)	2x (1/0 to 500)	2x (2/0 to 500)
220 to 240	1x (10 to 1/0)	1x (10 to 1/0)	1x (8 to 1/0)	1x (6 to 1/0)	1x (4 to 1/0)	1x (4 to 1/0)	1x (3 to 1/0)	1x (1 to 3/0)	1x (2/0 to 3/0)	1x (3/0 to 250)	1x (250)	2x (2/0 to 500)
380 to 416	1x (10 to 1/0)	1x (10 to 1/0)	1x (10 to 1/0)	1x (8 to 1/0)	1x (8 to 1/0)	1x (6 to 1/0)	1x (6 to 1/0)	1x (4 to 1/0)	1x (3 to 1/0)	1x (3 to 1/0)	1x (1/0 to 3/0)	1x (3/0 to 250)
440 to 480	1x (10 to 1/0)	1x (10 to 1/0)	1x (10 to 1/0)	1x (10 to 1/0)	1x (8 to 1/0)	1x (8 to 1/0)	1x (6 to 1/0)	1x (6 to 1/0)	1x (4 to 1/0)	1x (3 to 1/0)	1x (1 to 3/0)	1x (2/0 to 3/0)
600	1x (10 to 1/0)	1x (10 to 1/0)	1x (10 to 1/0)	1x (10 to 1/0)	1x (10 to 1/0)	1x (8 to 1/0)	1x (8 to 1/0)	1x (6 to 1/0)	1x (6 to 1/0)	1x (4 to 1/0)	1x (3 to 1/0)	1x (1 to 3/0)
											5" (127 mm)	8" (203 mm)

Power Terminals

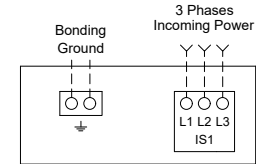

Bending Space	12" (305 mm)		16" (406 mm)					
HP Voltage	125	150	200	250	300	350	400	450
380 to 416	1x (250)	2x (1/0 to 500)	2x (3/0 to 500)	2x (4/0 to 500)	2x (300 to 500)	2x (400 to 500)	-----	-----
440 to 480	1x (3/0 to 250)	1x (4/0 to 250)	2x (1/0 to 500)	2x (3/0 to 500)	2x (4/0 to 500)	2x (300 to 500)	2x (350 to 500)	2x (400 to 500)
Bending Space	8" (203 mm)		12" (305 mm)					

ALUMINUM CONDUCTORS for Isolating Switch (IS1).

Field Wiring According to Bending Space (AWG or MCM). Terminals L1 - L2 - L3

Bending Space	5" (127 mm)							8" (203 mm)		10" (254 mm)	12" (305 mm)	
HP Voltage	5	7.5	10	15	20	25	30	40	50	60	75	100
200	1x (10 to 1/0)	1x (6 to 1/0)	1x (6 to 1/0)	1x (4 to 1/0)	1x (3 to 1/0)	1x (1 to 1/0)	1x (1/0)	1x (3/0)	1x (4/0 to 250)	1x (300)** or 1x (250) 90°C*	2x (2/0 to 500)	-----
208	1x (10 to 1/0)	1x (6 to 1/0)	1x (6 to 1/0)	1x (4 to 1/0)	1x (3 to 1/0)	1x (1 to 1/0)	1x (1/0)	1x (3/0)	1x (4/0 to 250)	1x (300)** or 1x (250) 90°C*	2x (2/0 to 500)	2x (4/0 to 500)
220 to 240	1x (10 to 1/0)	1x (8 to 1/0)	1x (6 to 1/0)	1x (4 to 1/0)	1x (3 to 1/0)	1x (2 to 1/0)	1x (1 to 1/0)	1x (2/0 to 3/0)	1x (3/0) 90°C*	1x (250)	1x (350)** N/A	2x (3/0 to 500)
380 to 416	1x (10 to 1/0)	1x (10 to 1/0)	1x (10 to 1/0)	1x (6 to 1/0)	1x (6 to 1/0)	1x (4 to 1/0)	1x (4 to 1/0)	1x (2 to 1/0)	1x (1 to 1/0)	1x (1/0)	1x (3/0)	1x (250 to 350)
440 to 480	1x (10 to 1/0)	1x (10 to 1/0)	1x (10 to 1/0)	1x (8 to 1/0)	1x (6 to 1/0)	1x (6 to 1/0)	1x (6 to 1/0)	1x (4 to 1/0)	1x (2 to 1/0)	1x (1 to 1/0)	1x (1/0 to 3/0)	1x (3/0)
600	1x (10 to 1/0)	1x (10 to 1/0)	1x (10 to 1/0)	1x (10 to 1/0)	1x (8 to 1/0)	1x (6 to 1/0)	1x (6 to 1/0)	1x (4 to 1/0)	1x (4 to 1/0)	1x (2 to 1/0)	1x (1 to 1/0)	1x (2/0 to 3/0)
											5" (127 mm)	8" (203 mm)

Bending Space	12" (305 mm)		16" (406 mm)					
HP Voltage	125	150	200	250	300	350	400	450
380 to 416	1x (350)**	2x (3/0 to 500)	2x (4/0 to 500)	2x (300 to 500)	2x (500)	3x (300 to 500)** 2x (500) 90°C*	-----	-----
440 to 480	1x (250)	1x (300 to 350)** 1x (250) 90°C*	2x (3/0 to 500)	2x (250 to 500)	2x (300 to 500)	2x (400 to 500)	2x (500)	2x (500) 90°C*
Bending Space	8" (203 mm)		12" (305 mm)					

Notes:

- For proper wire sizing, refer to NFPA70 and NEC (USA) or CEC (Canada) or local code.
- Controller suitable for service entrance in USA.
- For more accurate motor connections refer to motor manufacturer or motor nameplate.
- Controller is phase sensitive. Incoming lines must be connected in ZS sequence.

Drawing for information only.
Manufacturer reserves the right to modify this drawing without notice.
Contact manufacturer for "As Built" drawing.

*For standard enclosure, use 90°C aluminium wire. Consult Factory for Use of Conductors Rated Lower than 90°C.

** Consult Factory



© Firetrol, Inc. Not for construction.
Subject to change without notice.

BY		DD/MM/YY	
DRAWN BY	ZS	10/07/23	
FINAL APPROVAL	FC	10/07/23	

ELECTRIC FIRE PUMP CONTROLLER

MODEL:FTA3100S / FTA3130S

BUILT TO THE LATEST EDITION OF THE NFPA20 & NFPA70



DRAWING NUMBER	FC31X0S-801/E
DWG REV. 0	
SHEET 1 OF 1	

COPPER CONDUCTORS for Motor Connection (1M).

Field Wiring According to Bending Space (AWG or MCM). Terminals T1 - T2 - T3

HP Voltage	5	7.5	10	15	20	25	30	40	50	60	75	100
200	1x (10 to 2)	1x (8 to 2)	1x (8 to 2)	1x (6 to 2)	1x (4 to 2)	1x (3 to 2/0)	1x (2 to 2/0)	1x (1/0 to 3/0)	1x (3/0)	1x (4/0 to 300)	1x (300)	-----
208	1x (10 to 2)	1x (8 to 2)	1x (8 to 2)	1x (6 to 2)	1x (4 to 2)	1x (3 to 2/0)	1x (2 to 2/0)	1x (1/0 to 3/0)	1x (3/0)	1x (4/0 to 300)	1x (300)	2x (2/0 to 300)
220 to 240	1x (10 to 2)	1x (10 to 2)	1x (8 to 2)	1x (6 to 2)	1x (4 to 2)	1x (4 to 2/0)	1x (3 to 2/0)	1x (1/0 to 3/0)	1x (2/0 to 3/0)	1x (3/0)	1x (250 to 300)	2x (2/0 to 300)
380 to 416	1x (10 to 2)	1x (10 to 2)	1x (10 to 2)	1x (8 to 2)	1x (8 to 2)	1x (6 to 2)	1x (6 to 1/0)	1x (4 to 2)	1x (3 to 2/0)	1x (1 to 2/0)	1x (1/0 to 3/0)	1x (3/0)
440 to 480	1x (10 to 2)	1x (10 to 2)	1x (10 to 2)	1x (10 to 2)	1x (8 to 2)	1x (8 to 2)	1x (6 to 2)	1x (6 to 2)	1x (4 to 2/0)	1x (3 to 2/0)	1x (1 to 1/0)	1x (2/0 to 3/0)
600	1x (10 to 2)	1x (10 to 2)	1x (10 to 2)	1x (10 to 2)	1x (10 to 2)	1x (8 to 2)	1x (8 to 2)	1x (6 to 2)	1x (6 to 2)	1x (4 to 2/0)	1x (3 to 1/0)	1x (1 to 1/0)

HP Voltage	125	150	200	250	300	350	400	450
380 to 416	1x (250 to 300)	1x (300)	2x (3/0 to 300)	2x (4/0 to 300)	2x (300)	2x (400 to 500)	-----	-----
440 to 480	1x (3/0)	1x (4/0 to 300)	2x (1/0 to 300)	2x (3/0 to 300)	2x (4/0 to 300)	2x (300)	2x (350 to 500)	2x (400 to 600)

Motor Terminals

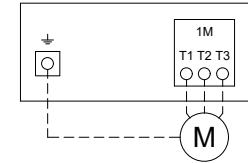

Models:FTA3100S / FTA3130S

ALUMINUM CONDUCTORS for Contactor (1M).

Field Wiring According to Bending Space (AWG or MCM). Terminals T1 - T2 - T3

HP Voltage	5	7.5	10	15	20	25	30	40	50	60	75	100
200	1x (10 to 2/0) **	1x (10 to 2/0) **	1x (6 to 2/0) **	1x (4 to 2/0) **	1x (2 to 2/0) **	1x (1 to 2/0) **	1x (1/0 to 2/0) **	1x (2/0) 90°C *	Consult Factory	1x (300)	1x (300) 90°C *	-----
208	1x (10 to 2/0) **	1x (10 to 2/0) **	1x (6 to 2/0) **	1x (4 to 2/0) **	1x (2 to 2/0) **	1x (1 to 2/0) **	1x (1/0 to 2/0) **	1x (2/0) 90°C *	Consult Factory	1x (300)	1x (300) 90°C *	2x (4/0 to 300)
220 to 240	1x (10 to 2/0) **	1x (10 to 2/0) **	1x (8 to 2/0) **	1x (4 to 2/0) **	1x (3 to 2/0) **	1x (2 to 2/0) **	1x (1 to 2/0) **	1x (2/0)	1x (3/0) 90°C *	Consult Factory	1x (300) 90°C *	2x (3/0 to 300)
380 to 416	1x (12 to 2/0) **	1x (12 to 2/0) **	1x (10 to 2/0) **	1x (8 to 2/0) **	1x (6 to 2/0) **	1x (6 to 2/0) **	1x (4 to 2/0) **	1x (2 to 2/0) **	1x (1 to 1/0)	1x (1/0)	1x (3/0)	Consult Factory
440 to 480	1x (12 to 2/0) **	1x (12 to 2/0) **	1x (10 to 2/0) **	1x (10 to 2/0) **	1x (8 to 2/0) **	1x (6 to 2/0) **	1x (6 to 2/0) **	1x (4 to 2/0) **	1x (2 to 1/0)	1x (1 to 1/0)	1x (1/0)	1x (3/0)
600	1x (12 to 2/0) **	1x (12 to 2/0) **	1x (12 to 2/0) **	1x (10 to 2/0) **	1x (10 to 2/0) **	1x (8 to 2/0) **	1x (8 to 2/0) **	1x (4 to 2/0) **	1x (4 to 2/0) **	1x (2 to 1/0)	1x (1 to 1/0)	Consult Factory

HP Voltage	125	150	200	250	300	350	400	450
380 to 416	1x (300) 90°C *	Consult Factory	2x (4/0 to 300)	2x (300)	Consult Factory	2x (600)	-----	-----
440 to 480	Consult Factory	1x (300)	2x (3/0 to 300)	2x (250 to 300)	2x (300)	2x (300) 90°C *	2x (500)	2x (600)

*For standard enclosure, use 90°C aluminium wire. Consult Factory for Use of Conductors Rated Lower than 90°C.

** Option V659 required.

Notes:

- For proper wire sizing, refer to NFPA70 and NEC (USA) or CEC (Canada) or local code.
- Controller suitable for service entrance in USA.
- For more accurate motor connections refer to motor manufacturer or motor nameplate.
- Controller is phase sensitive. Incoming lines must be connected in ZS sequence.

Drawing for information only.
Manufacturer reserves the right to modify this drawing without notice.
Contact manufacturer for "As Built" drawing.



© Firetrol, Inc. Not for construction.
Subject to change without notice.

BY		DD/MM/YY	
DRAWN BY	ZS	10/07/23	
FINAL APPROVAL	FC	10/07/23	

ELECTRIC FIRE PUMP CONTROLLER

MODEL:FTA3130S

BUILT TO THE LATEST EDITION OF THE NFPA20 & NFPA70



DRAWING NUMBER	FC3130S-800/E
DWG REV. 0	
SHEET 1 OF 1	

Field Connections

Terminals Wire Size:
24 - 12 AWG
0.5 Nm

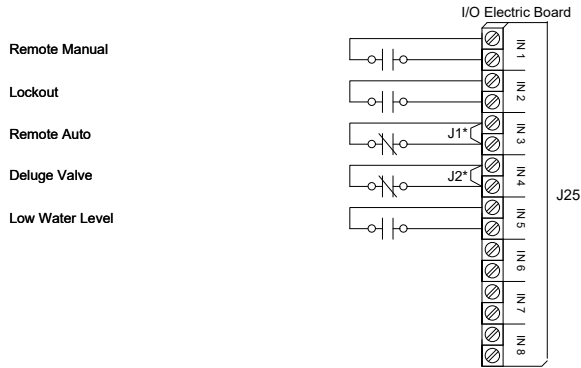

Network Connections

Terminals Wire Size:
Shielded Female Connector RJ45

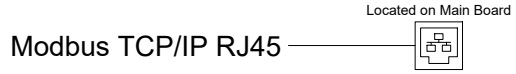

Alarm Contacts

Terminals Wire Size:
24 - 12 AWG
0.5 Nm

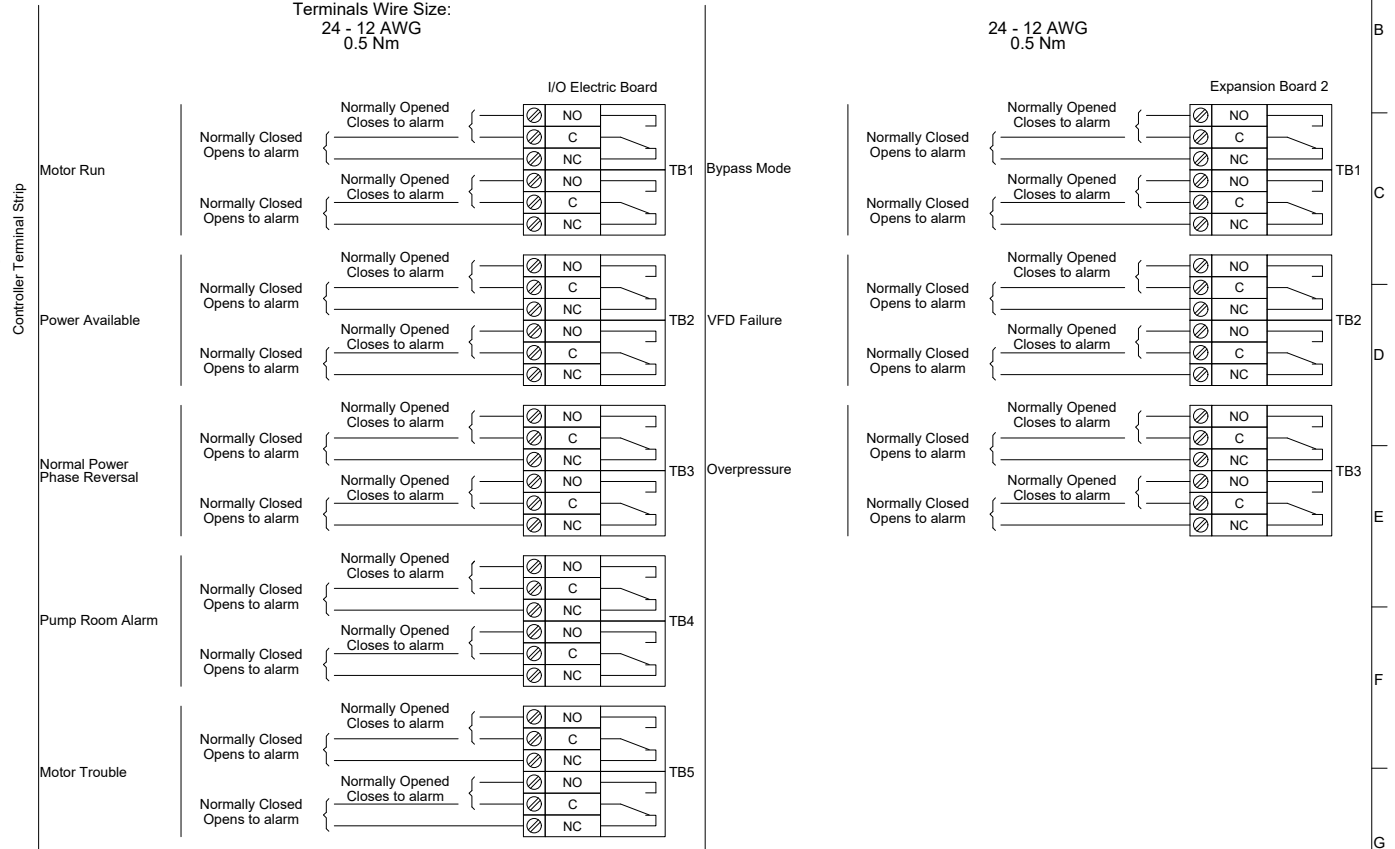

* Remove jumper to use this feature