

MARK^{III} Diesel Engine Fire Pump Controller

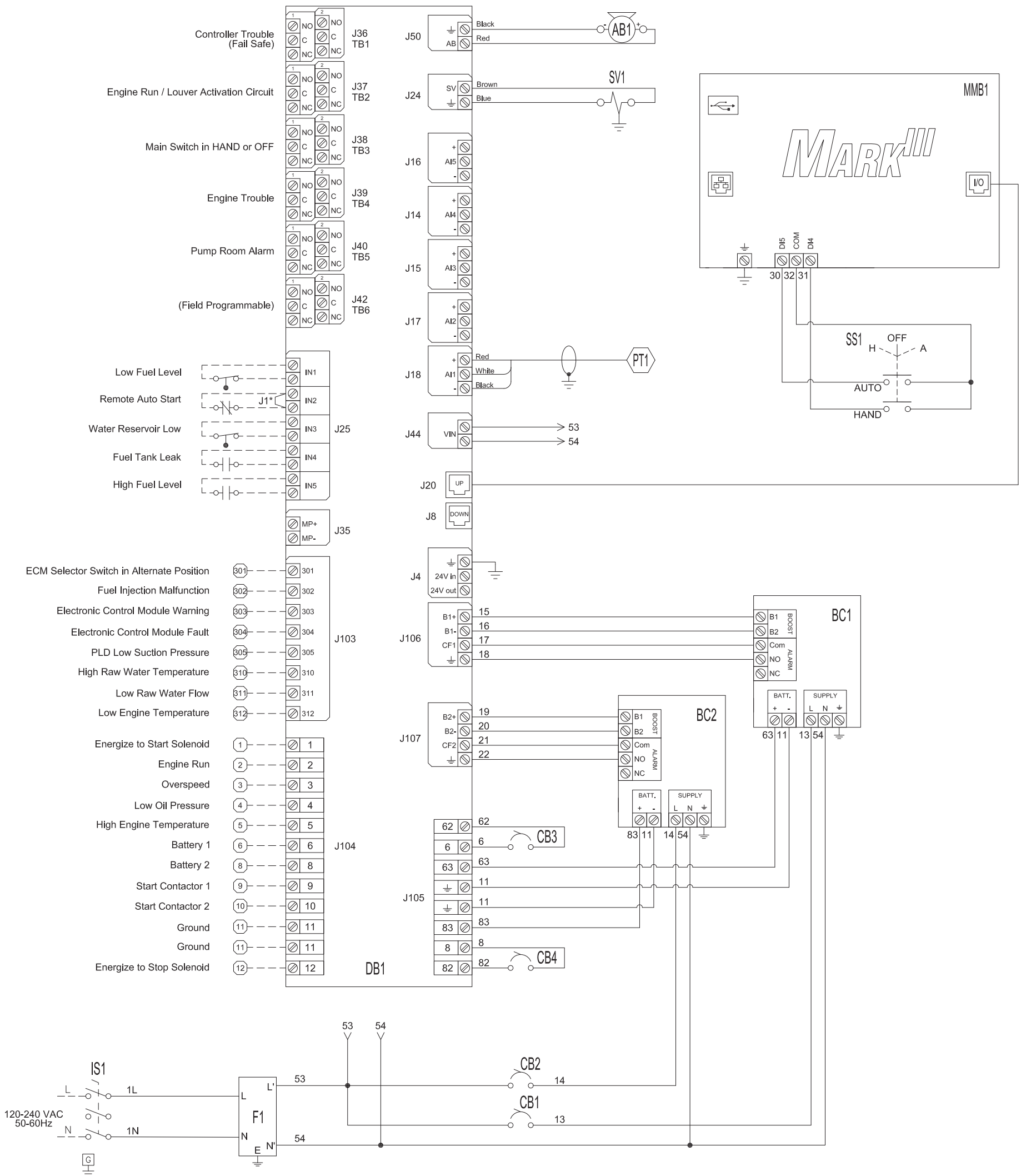

* Remove jumper to use this feature

| Legend | |
|--------|---------------------|
| AB | Alarm Bell |
| BC | Battery Charger |
| CB | Circuit Breaker |
| DB | Diesel I/O Board |
| F | Filter |
| IS | Isolating Switch |
| J | Jumper |
| PT | Pressure Transducer |
| SS | Selector Switch |
| SV | Solenoid Valve |
| MMB | Mark III Main Board |

Drawing for information only.
 Manufacturer reserves the right to modify this drawing without notice.
 Contact manufacturer for "As Built" drawing.

| SIZE | BY | DATE | REVISION DESCRIPTION | REV | ECN NO | BY | APP | DATE |
|--|-----|---------|------------------------------------|----------------|--------|--------------|-----|------|
| B | JMW | 12-2-19 | WIRING SCHEMATIC | | | | | |
| | CIR | 12-2-19 | DIESEL ENGINE FIRE PUMP CONTROLLER | | | | | |
| | | | FTA1100 | DRAWING NUMBER | | WS1100-30 | | |
| © Firetrol, Inc. Not for construction. Subject to change without notice. | | | 12VDC OR 24VDC NEGATIVE GROUND | DWG REV | ECN NO | SHEET 1 OF 1 | | |

All rights reserved. The drawing and the information contained or depicted herein are the sole property of Firetrol, Inc. Copies are communicated to the recipient in strict confidence and may not be retransmitted, published, reproduced, copied or used in any manner, including as the basis for the manufacture or sale of any products, without the express prior written consent of Firetrol, Inc.