

MARK^{III} Electric Fire Pump Controllers - Autotransformer Starting With Power Transfer Switch

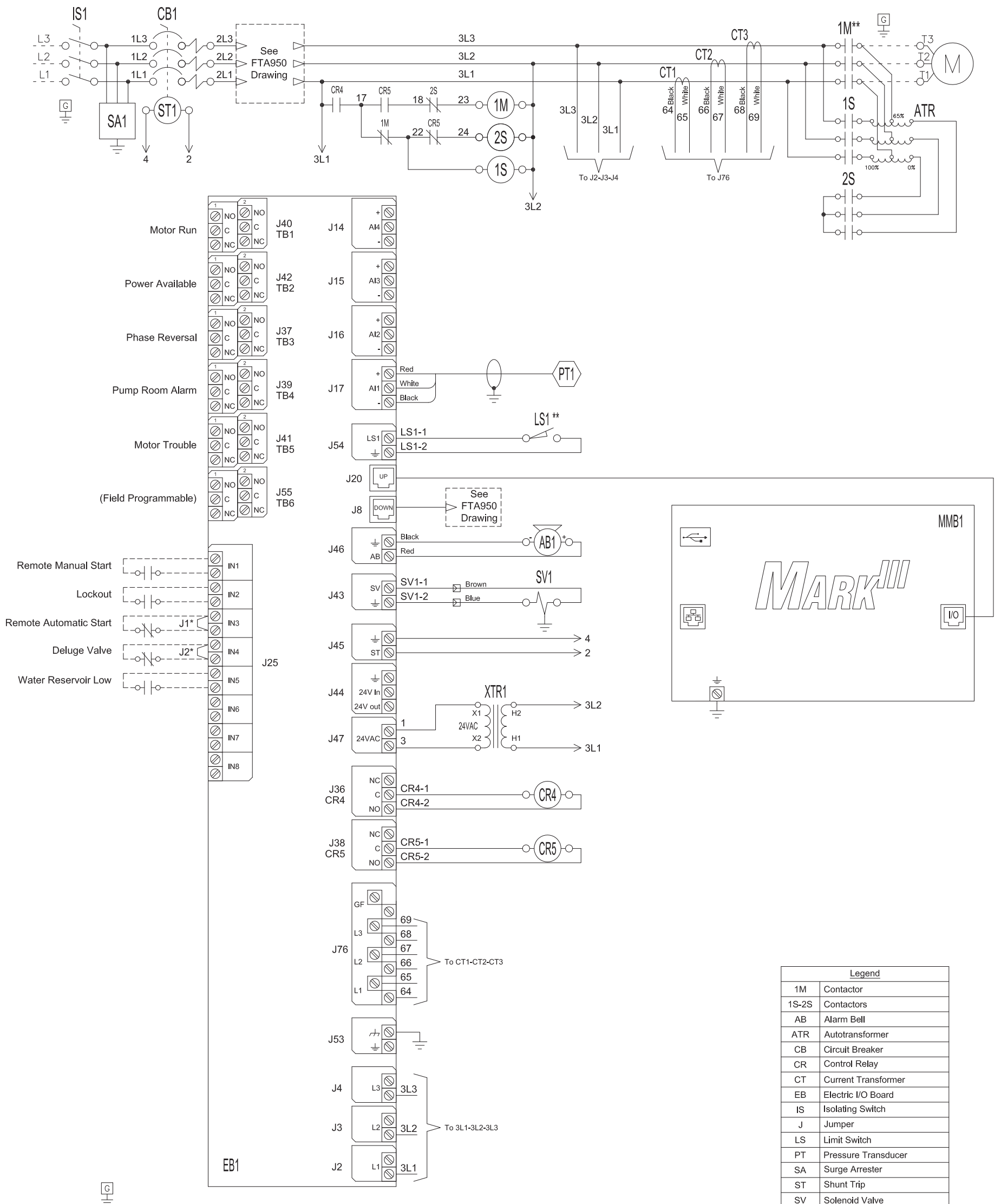

* Remove jumper to use this feature
 ** Contact closes when emergency start is in "ON" position

Drawing for information only.
 Manufacturer reserves the right to modify this drawing without notice.
 Contact manufacturer for "As Built" drawing.

	SIZE	B	BY	DATE	<p>© Firetrol, Inc. Not for construction. Subject to change without notice.</p>	REVISION DESCRIPTION				
	DRAWN BY	JMW	12-2-19			WIRING SCHEMATIC	FTA1800 W/FTA950			
	FINAL APPROVAL	CIR	12-2-19			AUTOTRANSFORMER FIRE PUMP CONTROLLER WITH POWER TRANSFER SWITCH		DRAWING NUMBER		WS1800-80
						DWG REV	ECN NO	BY	APP	DATE
										SHEET 1 OF 1

All rights reserved. The drawing and the information contained or depicted herein are the sole property of Firetrol, Inc. Copies are communicated to the recipient in strict confidence and may not be retransmitted, published, reproduced, copied or used in any manner, including as the basis for the manufacture or sale of any products, without the express prior written consent of Firetrol, Inc.