

MARK^{III} Limited Service Electric Fire Pump Controllers - Across The Line Starting With Power Transfer Switch

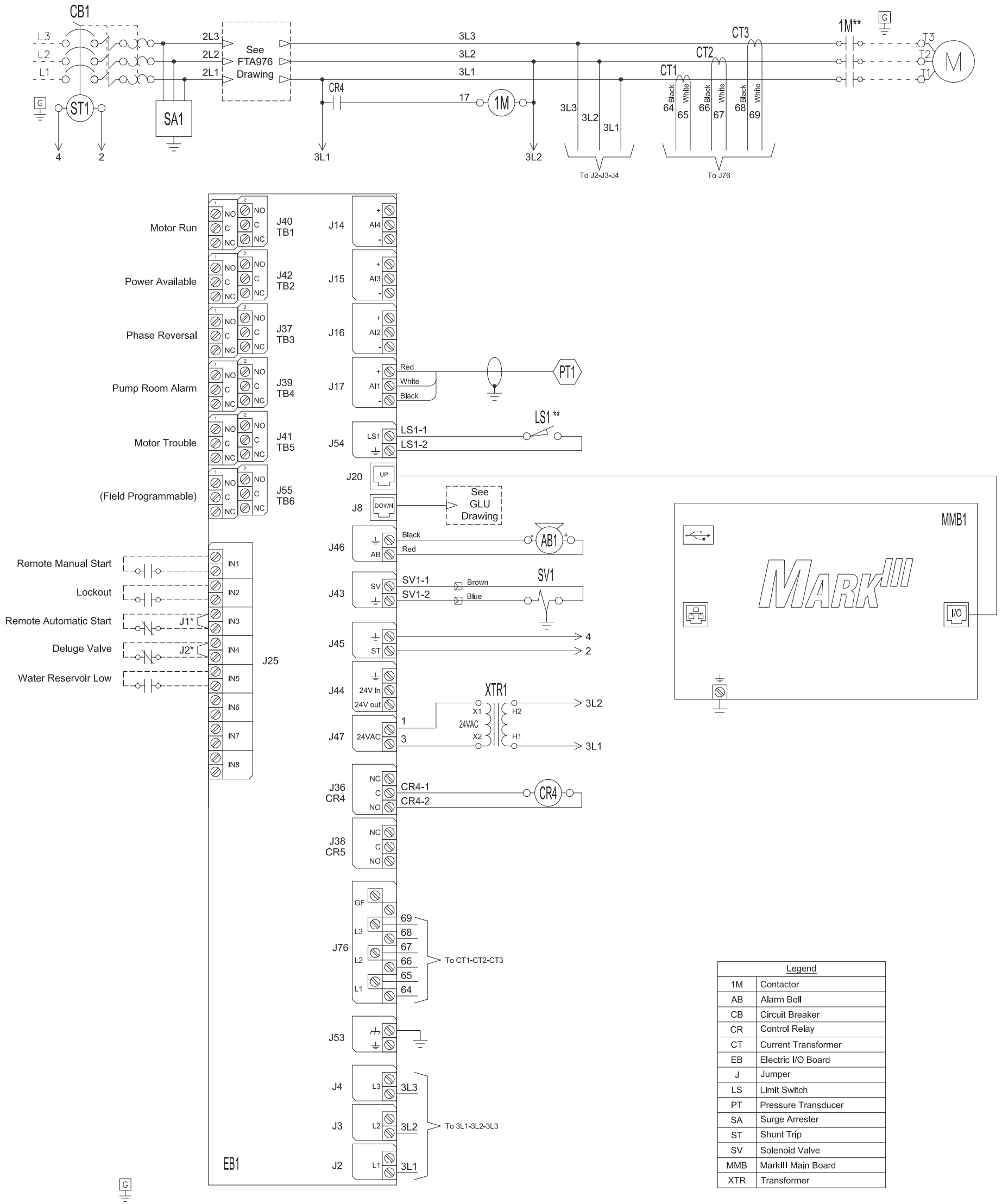

* Remove jumper to use this feature
 ** Contact closes when emergency start is in "ON" position

Drawing for information only.
 Manufacturer reserves the right to modify this drawing without notice.
 Contact manufacturer for "As Built" drawing.

	SIZE	B	BY	DATE	<p>© Firetrol, Inc. Not for construction. Subject to change without notice.</p>	REVISION DESCRIPTION				REV	ECN NO	BY	APP	DATE
	DRAWN BY	JMW	12-2-19	WIRING SCHEMATIC		FTA750 WITH FTA976		DRAWING NUMBER			WS750-80			
	FINAL APPROVAL	CIR	12-2-19	LIMITED SERVICE FIRE PUMP CONTROLLER WITH POWER TRANSFER SWITCH		DWG NO -			ECN NO -			SHEET 1 OF 1		