

Power Transfer Switch For Use With MARK^{III} Electric Fire Pump Controllers

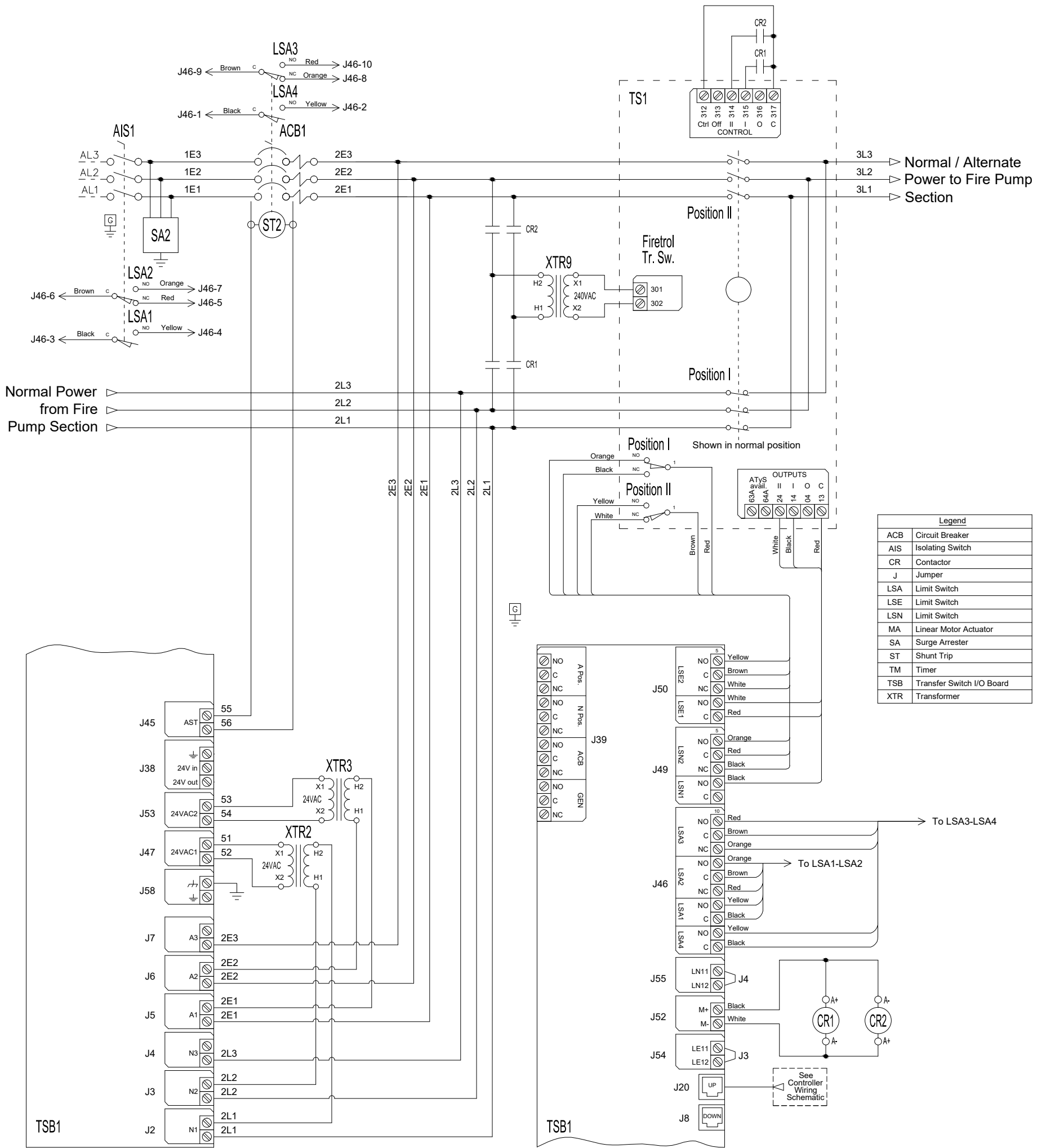

Drawing for information only.
Manufacturer reserves the right to modify this drawing without notice.
Contact manufacturer for "As Built" drawing.

VOLTAGE/POWER TABLE	
LINE VOLTAGE	MOTOR HORSEPOWER
380-415	15-200
440-480	15-250
550-600	15-350

	SIZE B	BY	DATE	<p>© Firetrol, Inc. Not for construction. Subject to change without notice.</p>	REVISION DESCRIPTION	FTA950	REV	ECN NO	BY	APP	DATE	
	DRAWN BY	CIR	12-9-19		WIRING SCHEMATIC	FW950	DRAWING NUMBER		WS950-60			
	FINAL APPROVAL	CIR	12-9-19		FIRE PUMP TRANSFER SWITCH FOR GEN SET AND SECOND UTILITY POWER SOURCE FOR 380-600V		DWG REV	ECN NO	SHEET 1 OF 1		CDL	

All rights reserved. The drawing and the information contained or depicted herein are the sole property of Firetrol, Inc. Copies are communicated to the recipient in strict confidence and may not be retransmitted, published, reproduced, copied or used in any manner, including as the basis for the manufacture or sale of any products, without the express prior written consent of Firetrol, Inc.